

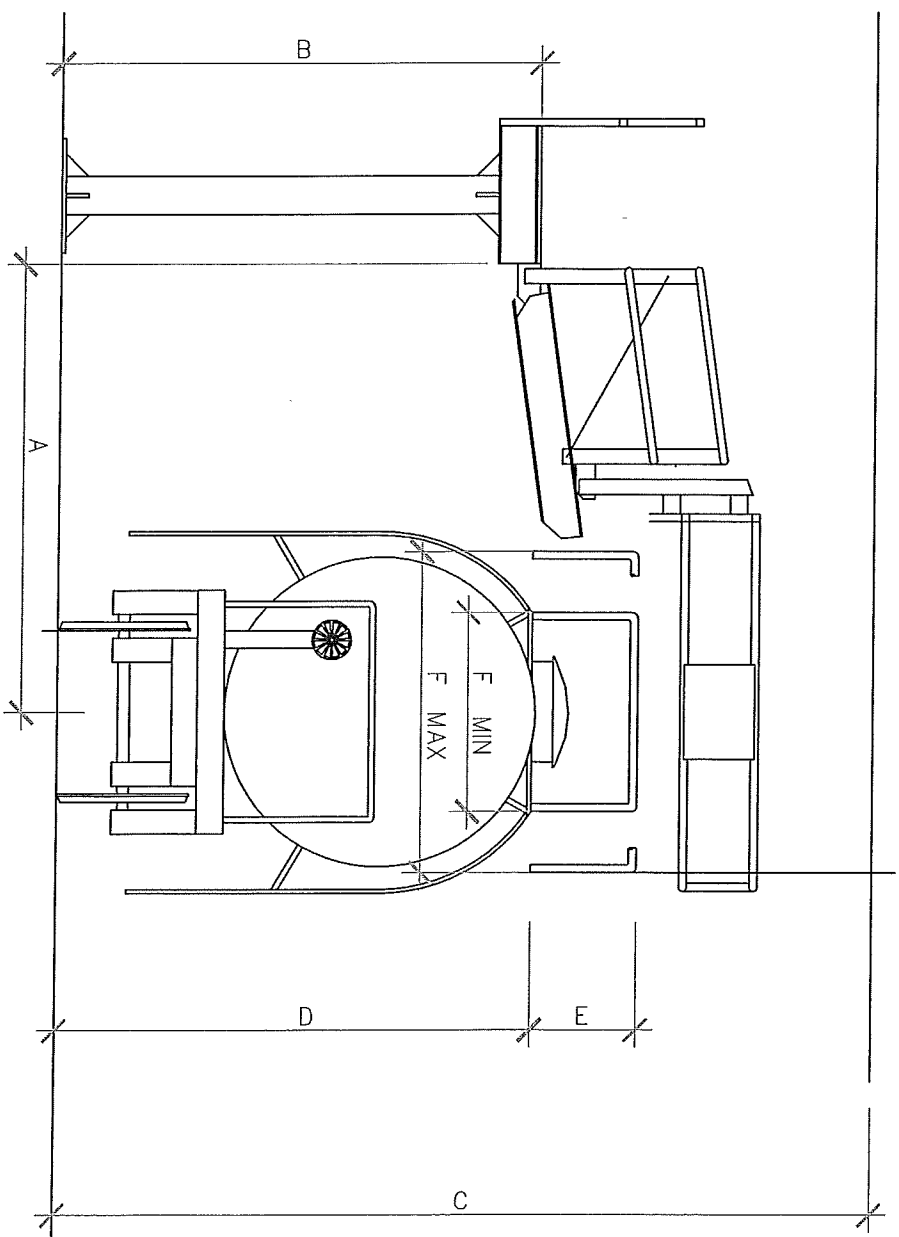

The Industry's Most Trusted Name

CUSTOMER NAME: _____ DATE: _____
 LOCATION: _____ NAME: _____
 CUSTOMER CONTACT: _____ JOB NO.: _____
 PHONE NUMBER: _____
 FAX NUMBER: _____
 EMAIL: _____

RAIL CAR HAULING LIQUID - YES OR NO _____
 RAIL CAR HAULING SOLID - YES OR NO _____



- _____ "A" DISTANCE FROM FACE OF PLATFORM TO CENTERLINE OF LOADING / UNLOADING HATCH / CAR
- _____ "B" DISTANCE FROM PLATFORM WALK SURFACE TO TOP OF RAIL
- _____ "C" HEIGHT OF CLOSEST OVERHEAD OBSTRUCTIONS
- _____ "D" HEIGHT OF RAIL CAR WALK SURFACE TO TOP OF RAIL
- _____ "E" HEIGHT OF CRASH BOX
- _____ "F" WIDTH OF CRASH BOX (MIN. _____ MAX. _____)
- _____ LENGTH OF CRASH BOX (MIN. _____ MAX. _____)
- _____ HANDRAIL OPENING ON EXISTING PLATFORM (STANDARD 42")
- _____ CAGE NEEDED FOR FALL PROTECTION (YES/NO)
- _____ SIZE OF CAGE (8' X 8' - 2 RAIL)
- _____ STYLE OF GAGWAY
- _____ FLAT RAMP WITH EXTENSIONS (FRT)
- _____ MOUNTING TO EXISTING PLATFORM WITH STANDARD MOUNTS (YES/NO)
- _____ NEW PLATFORM REQUIRED (YES/NO)
- _____ RAILROAD CLEARANCE REQUIRED _____

COMMENTS:

