

# OPW<sup>®</sup> Engineered Systems

PART OF OPW FLUID TRANSFER GROUP

A **DOVER** COMPANY



## **ENDURA™ SERIES LOADING ARMS** *Advanced Loading Arm Technology*

**IMPROVING THE SAFETY AND EFFICIENCY IN PLANTS AROUND THE WORLD SINCE 1892.**

OPW Engineered Systems, part of OPW Fluid Transfer Group, provides expert solutions for the safe handling, transfer, monitoring, measuring and protection of hazardous bulk products worldwide.

**Fixed-Style**



EJ-32-F

**Scissor-Style**

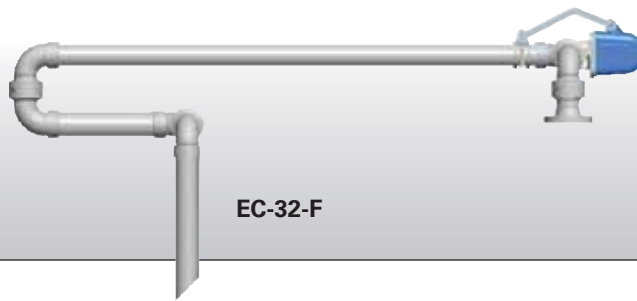

EC-32-F



**There is a Difference...**

**Endurance**

Heavy-duty construction and unique design features result in long-life, hassle-free operation

**Improves Uptime Performance**

Endura DSF swivel technology combined with the most user-friendly counterbalance solutions results in LESS DOWNTIME—LESS LABOR—LESS COST!

**Lowest Overall Cost of Ownership**

Optimized performance, downtime prevention and reduced maintenance time and costs make this the best overall loading arm solution in the industry.

**Premium Counter-Balance Technology**

- 790 Series EZ-Adjust Torsion Spring-Balance Units
- Infinite, Easy and Precise Spring-Balance Adjustment
- Provides Wide Range of Motion
- Turn-of-the-Wrench Adjustment Eliminates Labor-Intensive Steps
- Integral Spring Containment Safety Feature



**Termination Connections**



**Kamlok®**

- Highest alloys and gasket materials to endure the harshest environments
- Twin-Kam™ arms with special detent secure arms in position to prevent accidental uncoupling
- Finger rings do not get trapped under the coupling arms



**Autolok®**

- Provides extra protection against accidental release or uncoupling
- Arms lock automatically with a positive click
- If our exclusive Twin-Kam™ arms ever break they are replaced FREE



**Kamvalok®**

- Economical cam & groove dry disconnect coupler
- Prevents spillage at point of connection/disconnection
- Lever Action closes flow at both ends of connection



**DryLok™**

- Driest disconnect in the industry (less than 1cc from 3" fitting)
- Ideal for high-pressure applications
- 360° orientation ensures seating and alignment



**IMPORTANT:** OPW products should be used in compliance with applicable federal, state, provincial, and local laws and regulations. Product selection should be based on physical specifications and limitations and compatibility with the environment and materials to be handled. OPW MAKES NO WARRANTY OF FITNESS FOR A PARTICULAR USE. All illustrations and specifications in this literature are based on the latest product information available at the time of publication. OPW reserves the right to make changes at any time in prices, materials, specifications and models and to discontinue models without notice or obligation.

**Supported Boom-Type**

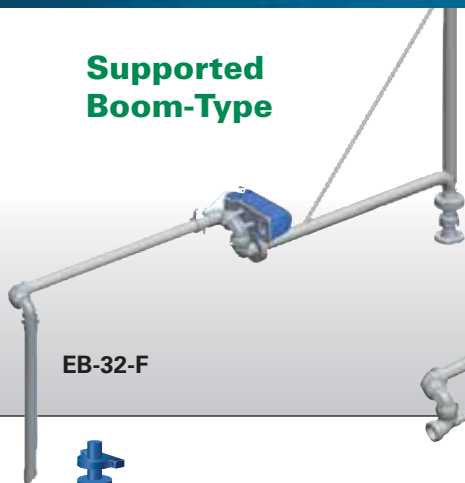

EB-32-F

**Unsupported Bottom Loader-Type**

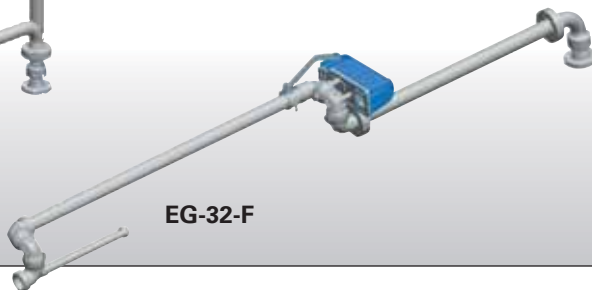

EG-32-F

**A-Frame Bottom Loader-Type**

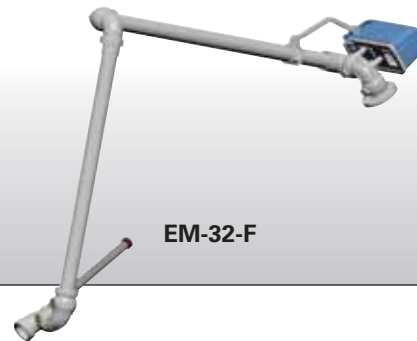

EM-32-F

**Endura™ Swivels**

**Redundant Sealing**

- Incorporates a main seal, back-up seal, static product seal and environmental seal
- If main product seal ever leaks due to normal wear, the back-up seal contains the fluid
- Any main seal leakage would be channeled to leak detection port
- Environmental seal provides a third layer of protection

**Bearing Module**

- Deep groove replaceable dual & single race ball bearing technology
- Easy replacement or rebuild options
- Ball removal not required to access main seals
- Endura 8800-8900 series feature ALL stainless steel construction

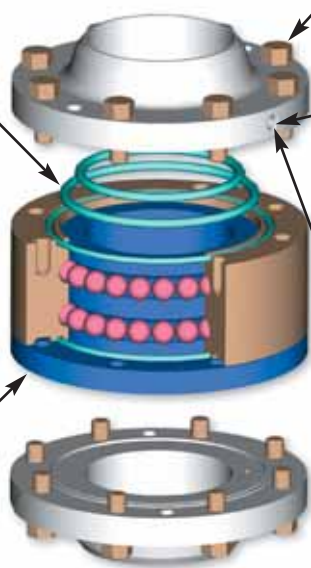

**Easy Maintenance**

- Simply unbolt sealing flanges to access seals
- No ball bearings to remove

**Leak Detection Port**

- In the event of main seal leakage, fluid would be channeled to leak detection port
- Quick & easy way to monitor performance so that maintenance can be performed

**Purge Port**

- For critical applications, an inert gas can be injected at leak detection/purge port
- Inert gas pressure higher than product pressure to virtually eliminate risk of fugitive emission.
- Recommended for your extreme applications!



**Pneumatically Actuated Packages**

- Push button pendant controller
- Can be designed to provide vertical and horizontal movement
- Can provide with complete pneumatic package or compressed air by others



**Epsilon™**

- High-flow dry disconnect
- Simple-to-use lever action
- Premium performance



**Tapered Hatch Cone**

- Steel, stainless steel or aluminum construction
- Economical – available in a variety of sizes
- Eliminates need for compressed air or gas line at loading point



**Hatch Cover Vapor Plate**

- Steel, stainless steel or aluminum construction
- Locking mechanisms/hold-down clamps
- Accommodates liquid sensing or overflow devices



**Inflatable Hatch Seal**

- Most effective means of open hatch vapor recovery currently available
- Reliably seals off different size and depth of hatch openings on rail cars and transports
- Available in EDPM and Nitrile



## Steam Jacketed

Endura Loading Arms are ideal for transfer of high melting point products such as molten sulphur, asphalt, resins and paraffins. DSF design minimizes need for steam jumpers, while maximizing heat transfer.

- Top and bottom loaders – fully or partially jacketed or traced
- Custom made to your specifications
- Durable for many years of service life

## Ground Verification

- CIVACON™ model 8030 Ground Verification Monitor
- Compatible with today's transport ground systems



- 5 amperage, 240 volt relay output for control of terminal automation systems(TAS) or pump control devices when used as a stand-alone system
- Equipped to provide a permissive signal to allow load rack operation and, if ground is lost, to indicate a non-permissive signal and shut down the loading operation

## Automatic Shutdown

Any Endura Loader can be equipped with an automatic shut-off feature to help prevent spillage and overfills.

- Electrical and pneumatic systems available
- Adjustable to stop flow at predetermined levels
- Can be configured to activate valves or alarms



## Loading Valves

- Designed to shut off flow without causing damaging shock in the pipeline
- Assures fast, shockless closing by use of adjustable needle valve, and dashpot
- Available in several styles to fill almost any liquid transfer requirement:
  - Vacuum Breakers
  - Specialty valves can also be provided



## Telescopic Drop Tube

Designed for applications which require sub-surface loading to minimize static, splashing or foaming.

- Can be designed for railcar or tank truck applications
- Eliminates need for extremely long drop tubes which can be difficult to maneuver and store



Engineered Systems

2726 Henkle Drive  
 Lebanon, OH 45036 USA  
 Telephone: 513-696-1500  
 Toll Free: 800-547-9393  
 Fax: 513-932-9845  
[www.opw-es.com](http://www.opw-es.com)